

	CODIGO	E	INS. [Kg.]	1° EXT. [Kg.]	10° EXT. [Kg.]	PARA MACHO Ø	MATERIAL	SECCION DEL CONDUCTOR [mm <sup>2</sup> ]
7	11033xx107 (33107)	0.30	≤ 3.0	≤ 2.2	≥ 0.6	2.75	LATON	0.50 / 1.50
7	11033xx110 (33110)	0.30	≤ 3.0	≤ 2.2	≥ 0.6	2.20	LATON	0.50 / 1.50
	11033xx135 (33135)	0.25	≤ 3.0	≤ 2.2	≥ 0.6	1.95	LATON	0.50 / 1.50
	11033xx147 (33147)	0.32	≤ 3.0	≤ 2.2	≥ 0.6	2.20	B. FOSF.	0.50 / 1.50
	11033xx155 (33155)	0.25	≤ 2.0	≤ 2.2	≥ 0.6	2.00	LATON	0.50 / 1.50
7	11033xx165 (33165)	0.30	≤ 3.0	≤ 2.2	≥ 0.6	3.00	LATON	0.50 / 1.50
7	11033xx199 (33199)	0.30	≤ 3.0	≤ 2.2	≥ 0.6	2.30	LATON	0.50 / 1.50
12	11033xx379 (33379)	0.35	≤ 3.0	—	≥ 0.6	4.00	LATON	0.50 / 1.50
10	11033xx421 (33421)	0.30	≤ 3.0	≤ 2.2	≥ 0.6	3.2	LATON	0.50 / 1.50

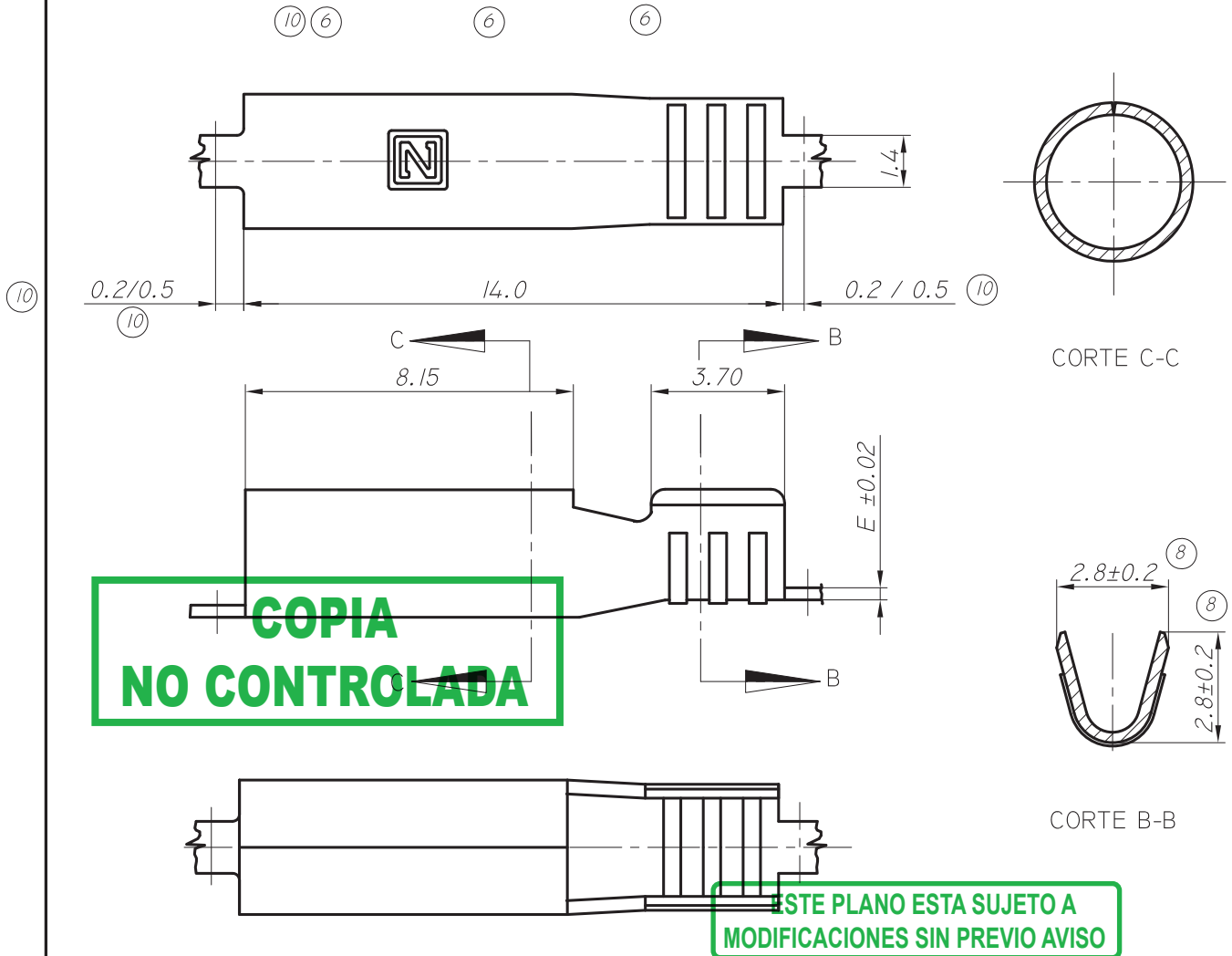

05.03.15	12	PARA COD. 33379 1° EXT. ERA ≤ 3.0 Y 10°EXT. ERA NADA.	L.L.		
27.04.09	11	PARA COD. 33379 1° EXT. ERA 1.75 / 3.0.	L.L.	O.A.C.	GARCIA
10.01.07	10	COTA ERA 0.5 MAX., SE AGREGA MINIMO Y PARA 33379 INS. ERA 1.75/3.0.	L.L.	O.A.C.	GARCIA
15.11.05	9	SE AGREGA PIEZA 33421.	L.L.	O.A.C.	GARCIA
FECHA	N°	MODIFICACIONES	DIBUJO	REVISO	APROBO



INDUSTRIAS ZETA S.R.L.

TOLERANCIA NO ACOTADA:

LINEAL: ±0.15

ANGULAR: ± 1° 30'

MATERIAL: VER TABLA	ESCALA: 5:1	DIBUJO	REVISO	APROBO
CODIGO MAS: /E = TERMINACION ESTAÑADA /N = TERMINACION NIQUELADA /P = TERMINACION PLATEADA /S = PIEZA SUELTA	HOJA: 1 DE 3	P.S.	O.A.C.	GARCIA
		18.06.02	18.06.02	18.06.02

DENOMINACION: TERMINAL TUBO HEMBRA

PLANO PARA CLIENTE N°: 33000